

Circuit Diagram 3HAC 13347-1 / Rev. 02

CONTENTS

Sheet

Contents	101
Connection Point Location	102
Legend	103
Brake Release Unit	104
Serial Measurement Board	105
Axis 1	106
Axis 2.....	107
Axis 3.....	108
Axis 4.....	109
Axis 5 (IRB 7600)	110
Axis 6.....	111
Switches axis 1	113
Switches/Fan axis 2	114
Switches/Fan axis 3	115
Axis 5 (IRB 6600)	901
Design changes, note 1.1	905
Design changes, note 2.1-2.7	906

SHEET BLAD	CONTENT INNEHÅLL
101	LIST OF CONTENTS INNEHÅLLSFÖRTECKNING
102	CONNECTION POINT LOCATIONS ÖVERSIKT ÖVER DELNINGSPUNKTER
103	LEGEND SYMBOLER
104	BRAKE RELEASE UNIT BROMSLOSSNINGSENHET
105	SERIAL MEASURING BOARD SERIEMÄTKORT
106	AXIS 1 AXEL 1
107	AXIS 2 AXEL 2
108	AXIS 3 AXEL 3
109	AXIS 4 AXEL 4
110	AXIS 5 IRB 7600 AXEL 5
111	AXIS 6 AXEL 6

SHEET BLAD	CONTENT INNEHÅLL
113	SWITCHES AXIS 1 BRYTARE AXEL 1
114	SWITCHES/FAN AXIS 2 BRYTARE/ FLÅKT AXEL 2
115	SWITCHES/FAN AXIS 3 BRYTARE/FLÅKT AXEL 3
901	AXIS 5 IRB 6600 AXEL 5
905	DESIGN CHANGES, NOTE 1.1 KOSTRUKTIONSÄNDRINGAR, NOT 1.1
906	DESIGN CHANGES, NOTE 2.1-2.7 KOSTRUKTIONSÄNDRINGAR, NOT 2.1-2.7

NOTES: SEE SHEET 905-906 FOR EARLIER DESIGN
NOT: SE BLAD 905-906 FÖR TIDIGARE KONSTRUKTION

1.1 VALID FOR 3HAC14940-1 REV.3 (IRB 6600,7600) AND 3HAC16331-1 REV.1 (IRB 6650) AND LATER REVISIONS
GÄLLER FÖR 3HAC14940-1 REV.3 (IRB 6600,7600) AND 3HAC16331-1 (IRB 6650) REV.1 OCH SENARE REVISIONER
SEE NOT 1.1

2.1-2.7 VALID FOR 3HAC14940-1 REV.6 AND 3HAC16331-1 REV.4 AND LATER REVISIONS
GÄLLER FÖR 3HAC14940-1 REV.6 AND 3HAC16331-1 REV.4 OCH SENARE REVISIONER
SEE NOT 2.1-2.7

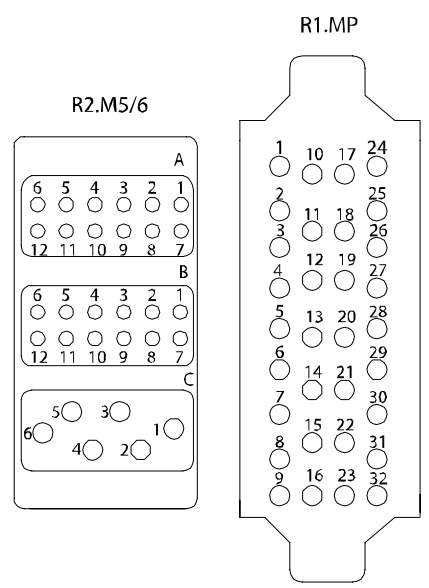
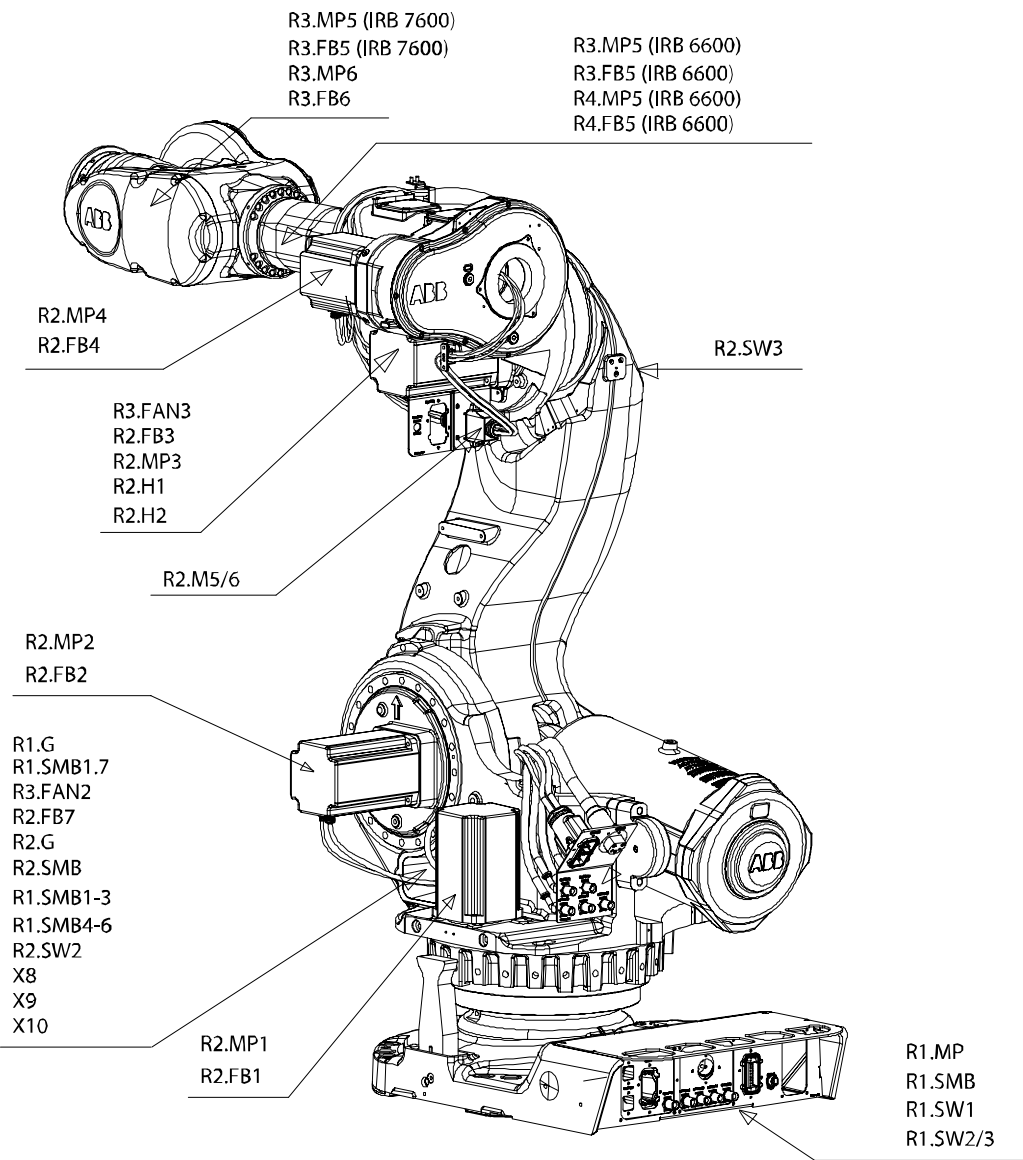

Contents

sheet	Revision
101	02



Connection Point Location

sheet		Revision
102		02

M	MOTOR MOTOR
B	BRAKE BROMS
PTC	TEMP SENSOR (PTC-resistor) TEMP GIVARE (PTC-motstånd)
R	RESOLVER RESOLVER
G	BATTERY PACK BATTERIENHET
BU	BRAKE RELEASE UNIT BROMSLOSSNINGSENHET
FB	FEED-BACK UNIT ÅTERFÖRINGSDON
SMB	SERIAL MEASURING BOARD SERIEMÄTKORT
FAN	FAN FLÄKT
SW	SWITCH BRYTARE
	PROTECTIVE EARTH SKYDDSJORD
	TWISTED CABLES TVINNADE LEDARE
	SCREENED CABLES SKÄRMMADE LEDARE
KEY PIN/STIFT	LOCATION PIN TO AVOID MISMATCH OF CONNECTOR NYCKELSTIFT FÖR ATT FÖRHINDRA FELANSLUTNING

Legend

sheet		Revision
103		02

BU BRAKE RELEASE (NOTE:SIMPLIFIED)

R1.MP

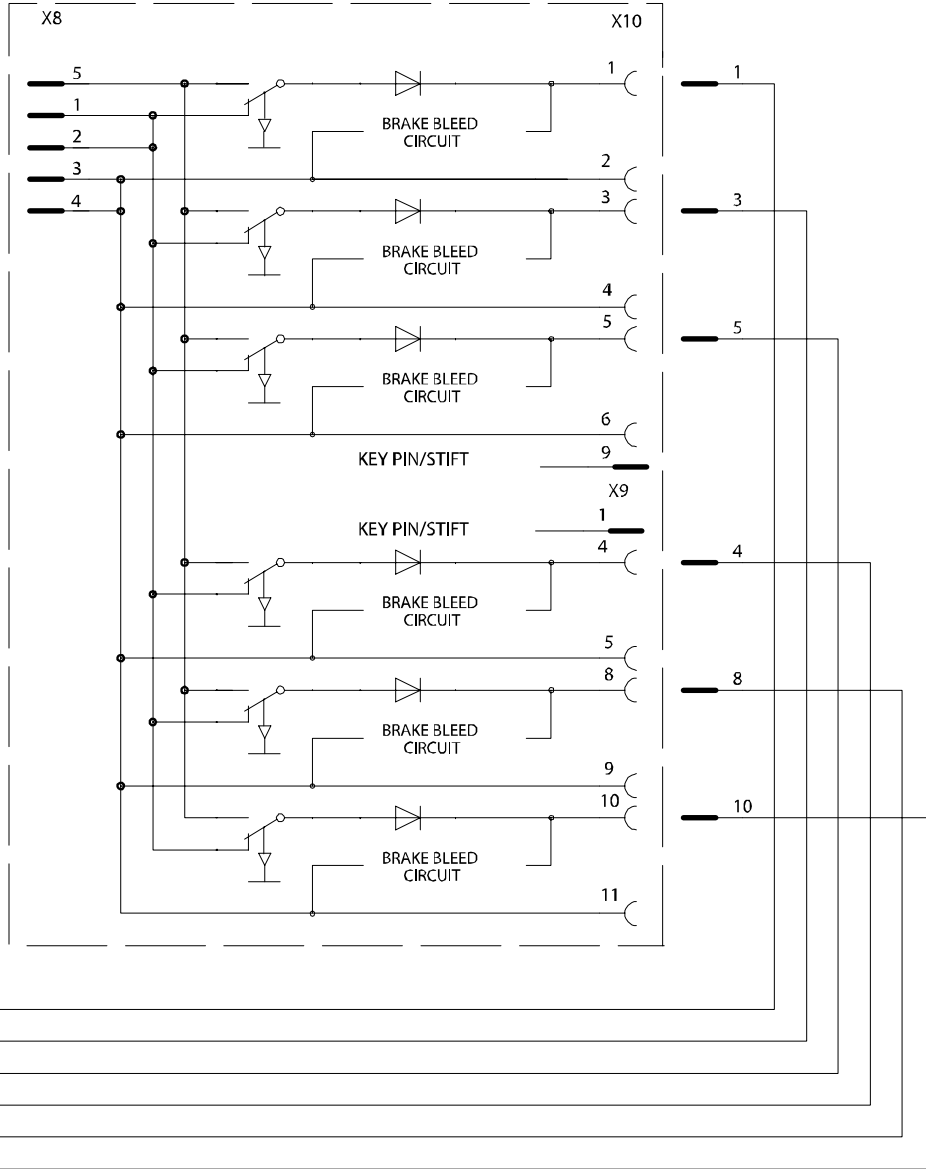
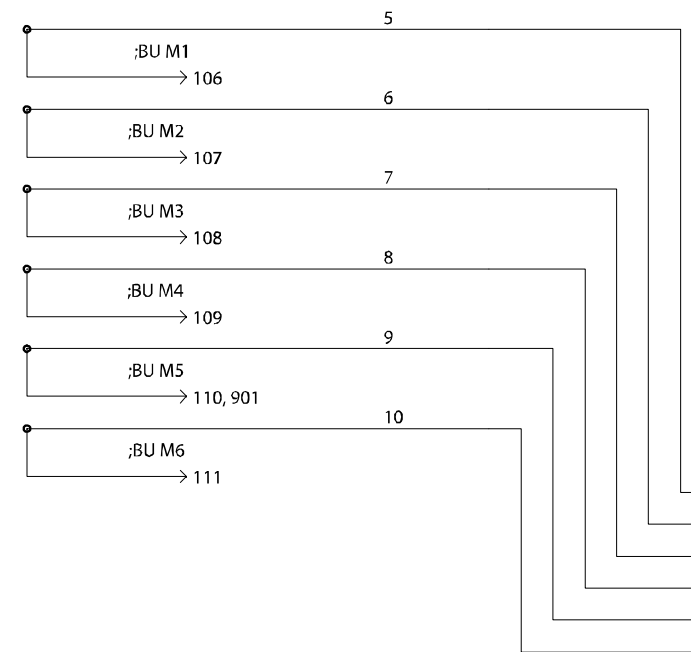
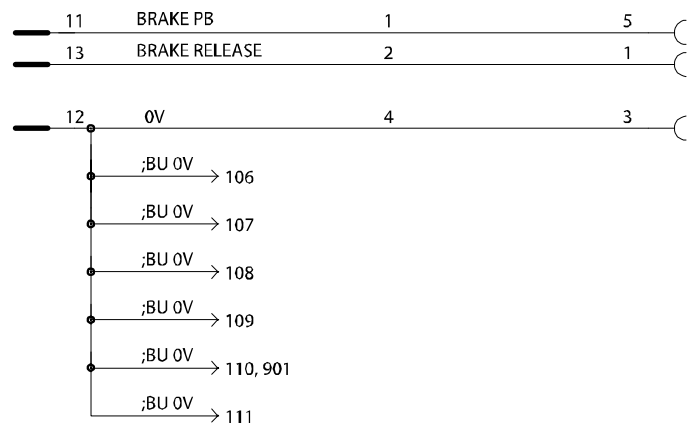

Brake Release Unit

sheet		Revision
104		02

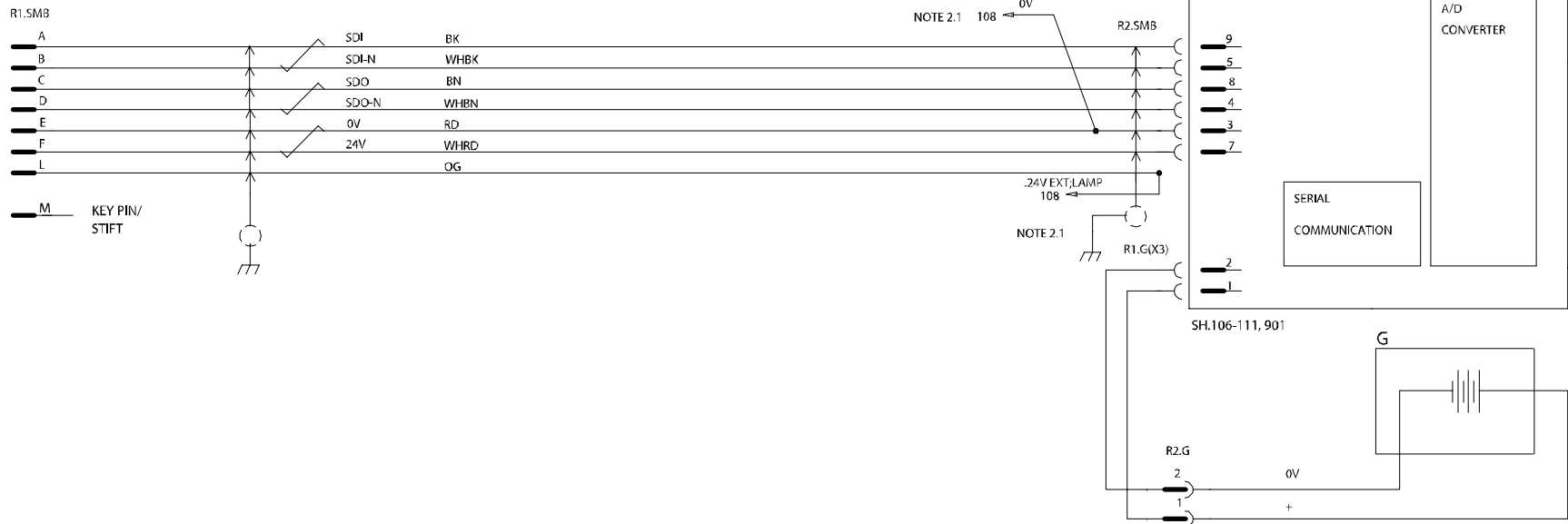

SMB

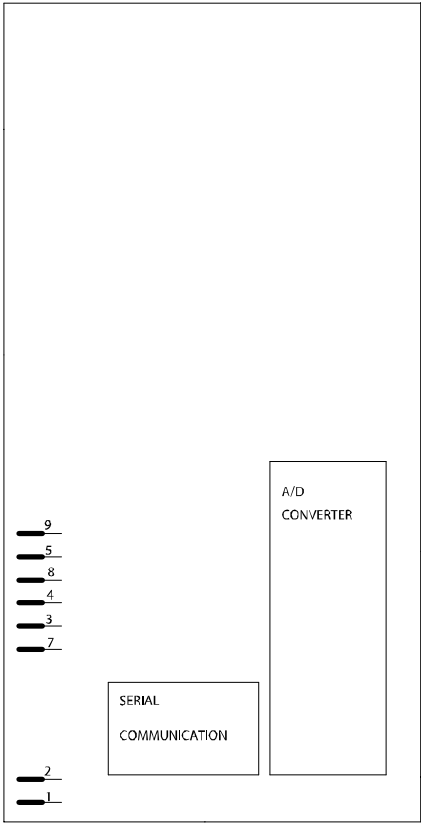

SH.106-111, 901

sheet		Revision
105		02

Serial Measurement Board

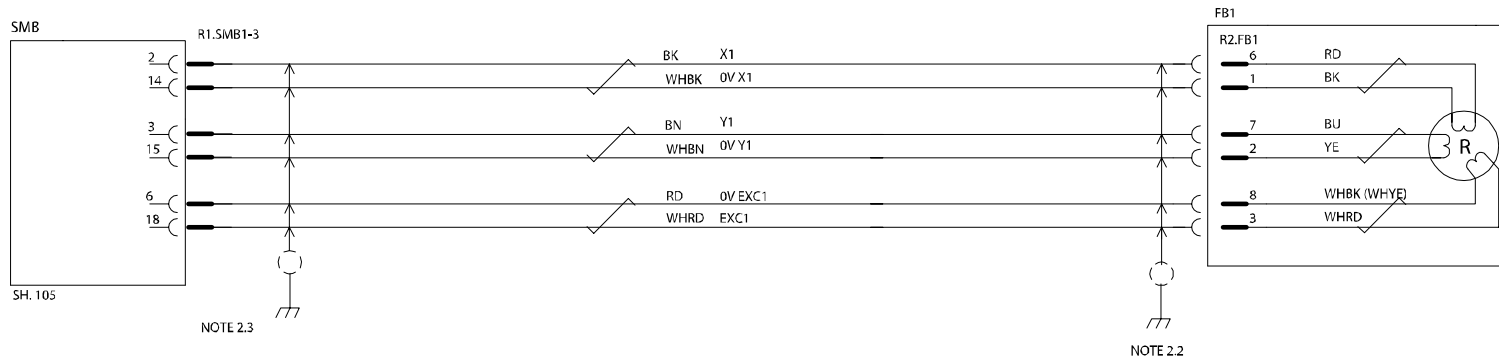
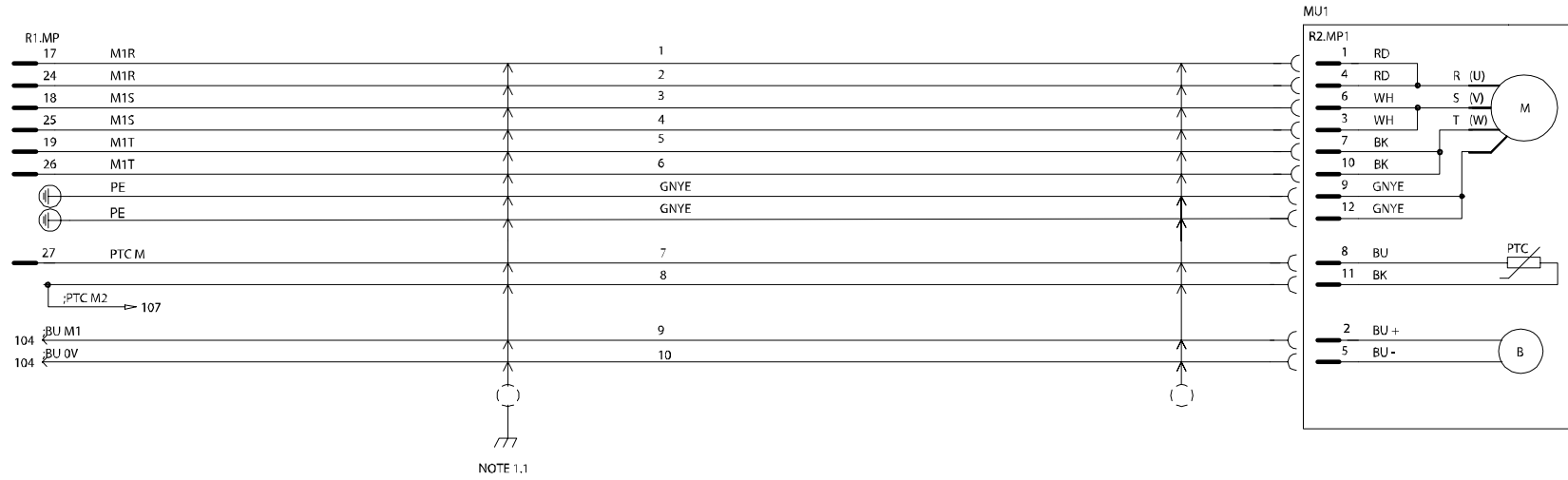

Axis 1

sheet		Revision
106		02

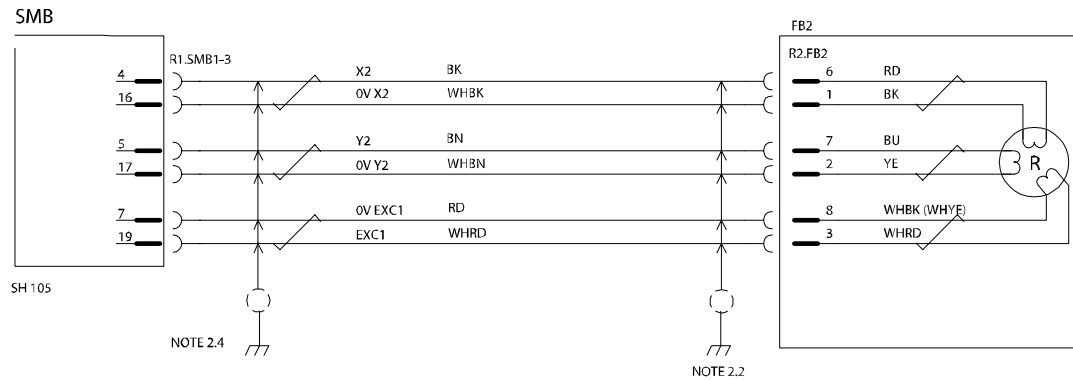
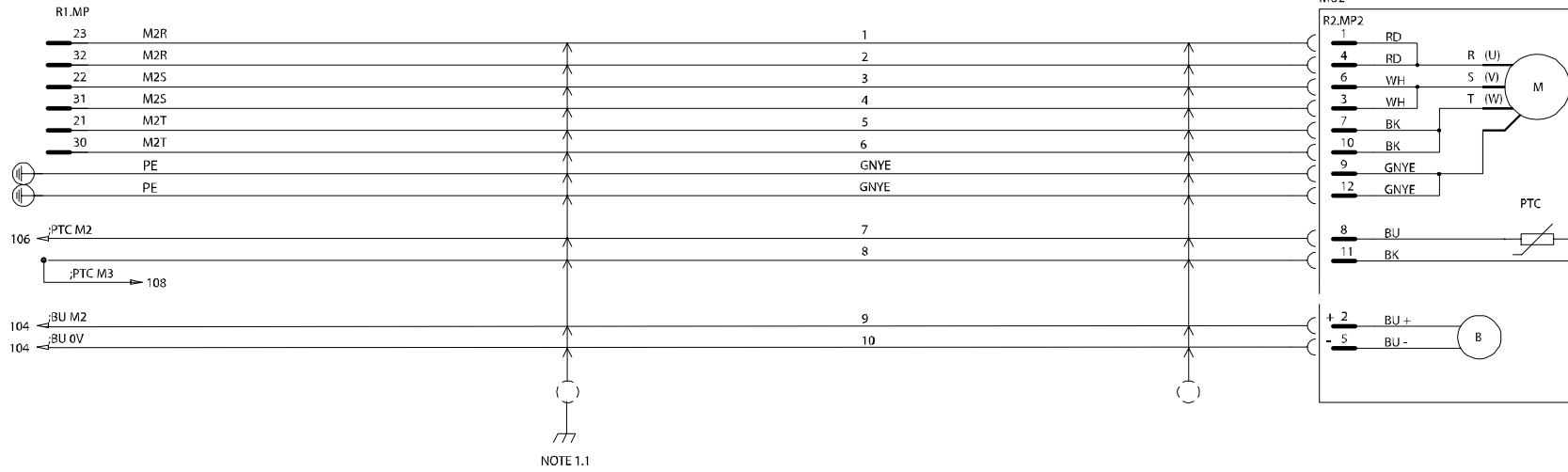

Axis 2

sheet		Revision
107		02

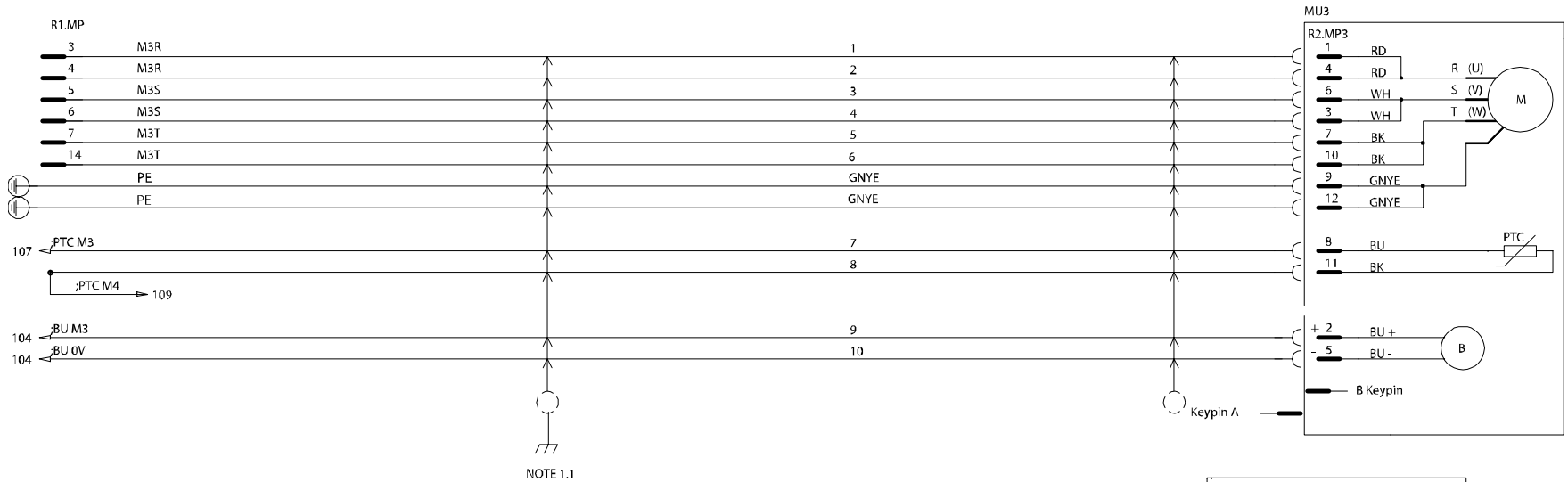

NOTE 1.1

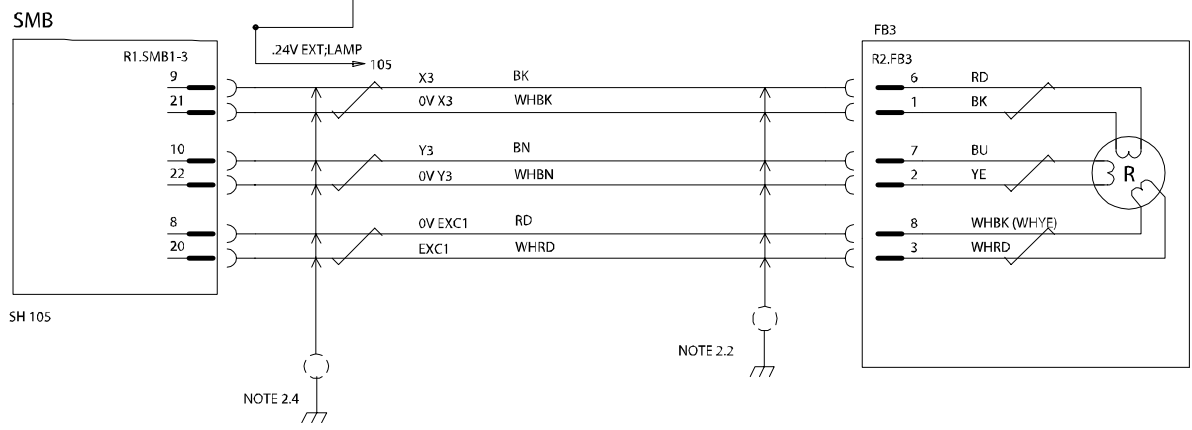
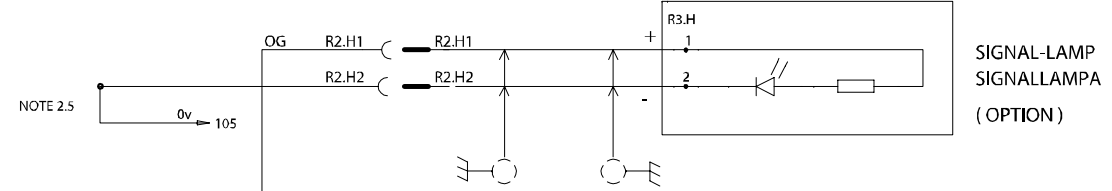

NOTE 2.2

Axis 3

sheet		Revision
108		02

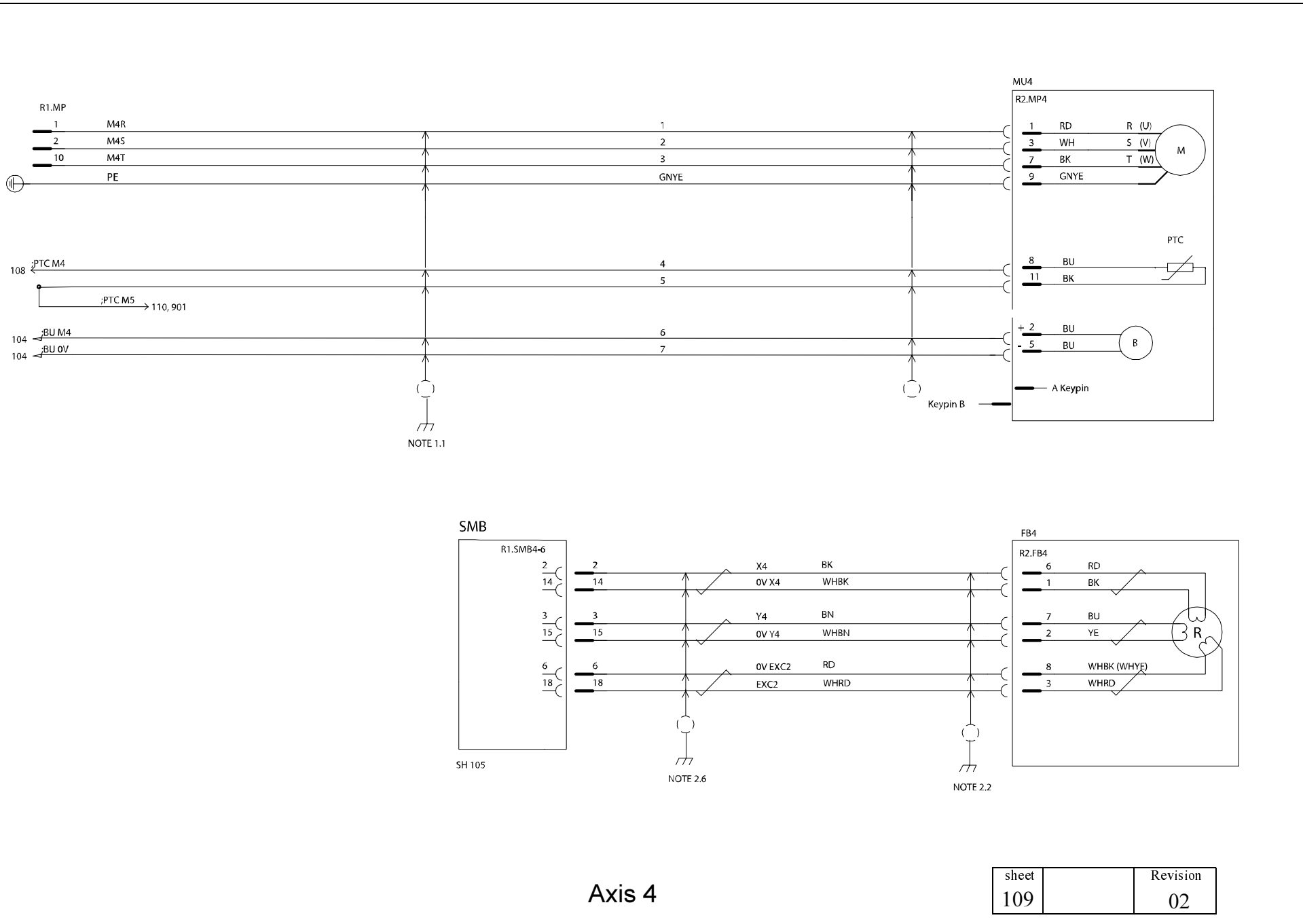

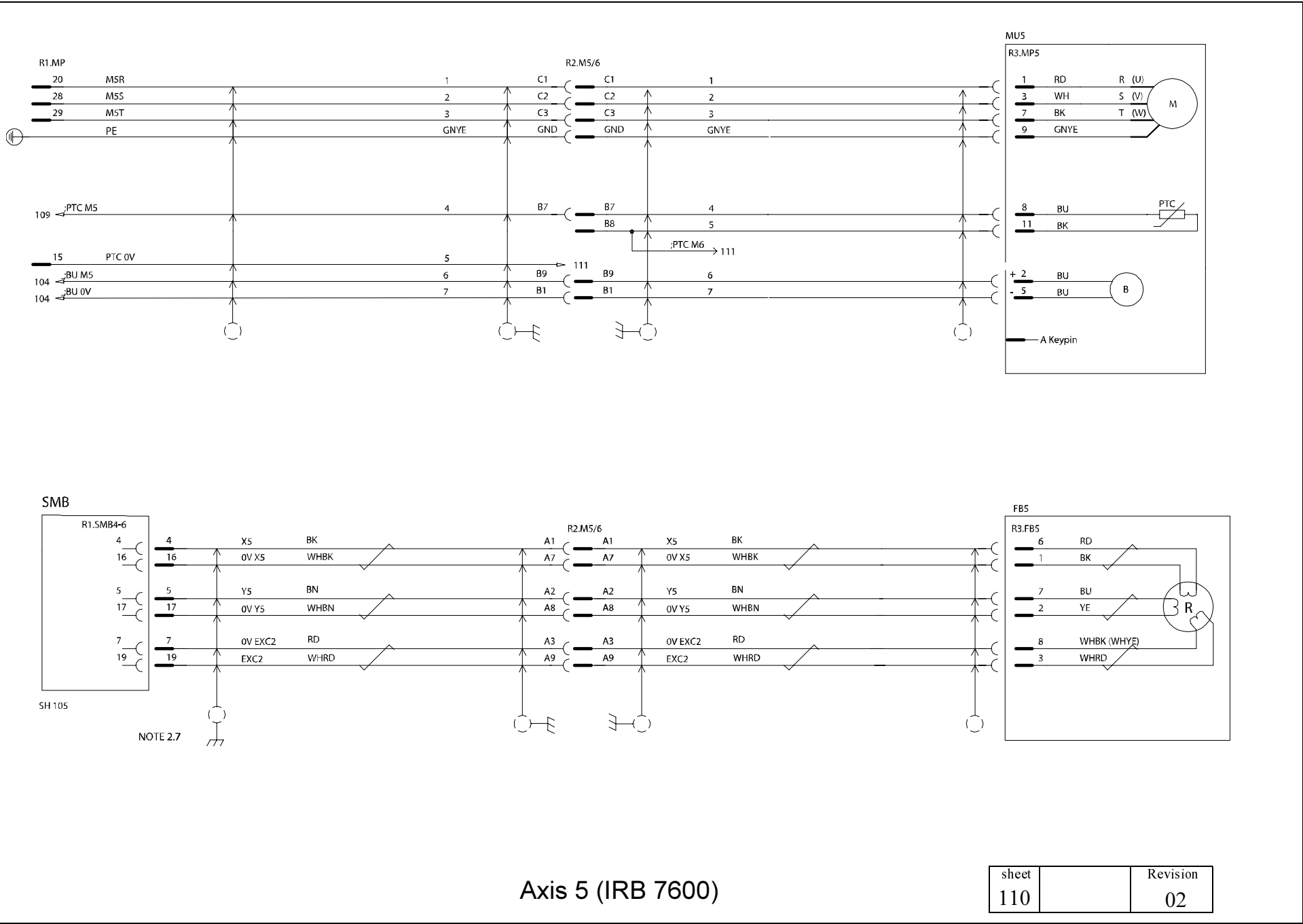

Circuit Diagram 3HAC 13347-1

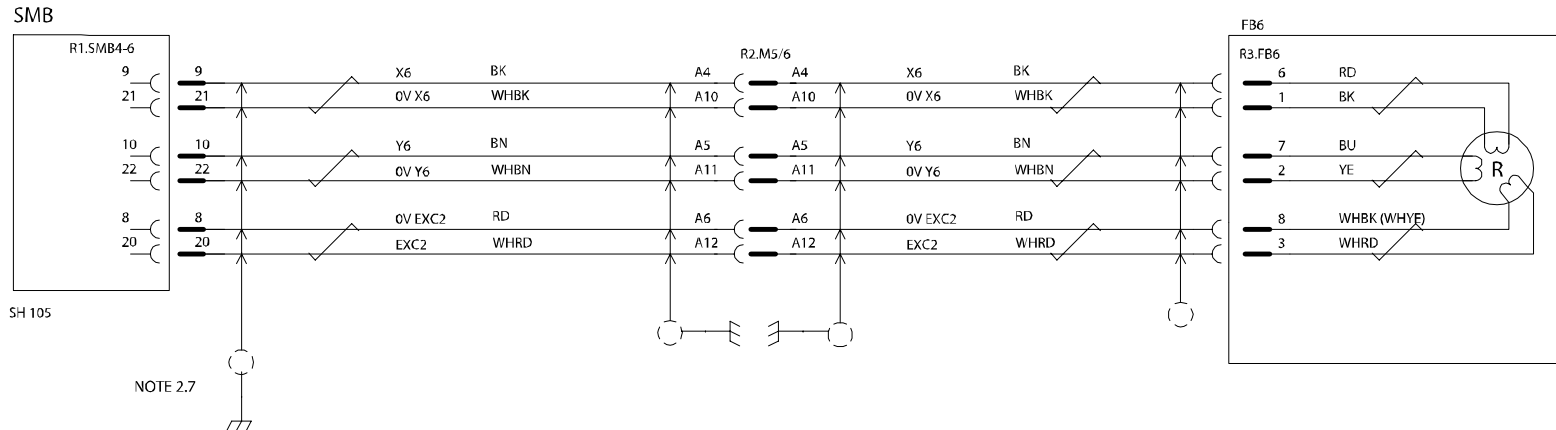
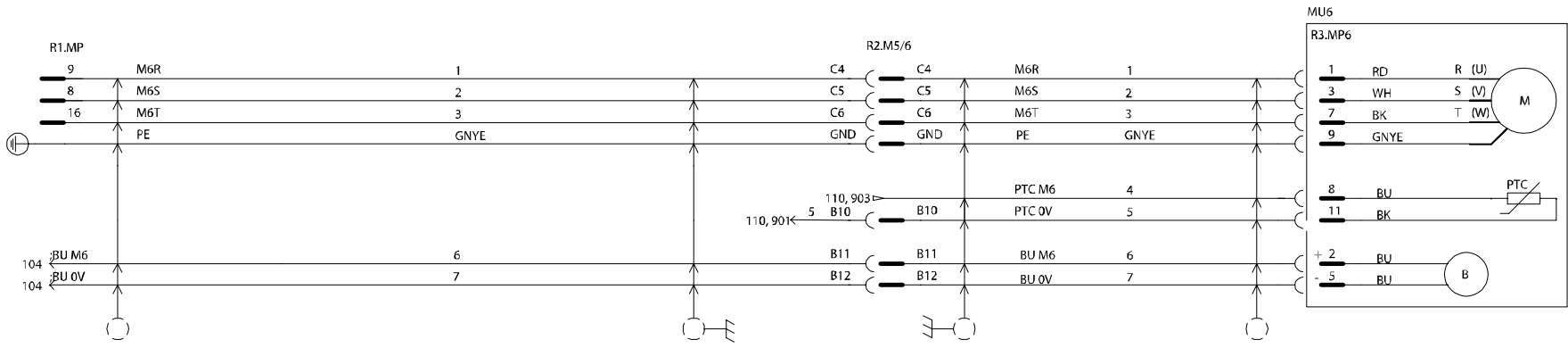

Axis 6

sheet		Revision
111		02

Circuit Diagram 3HAC 13347-1

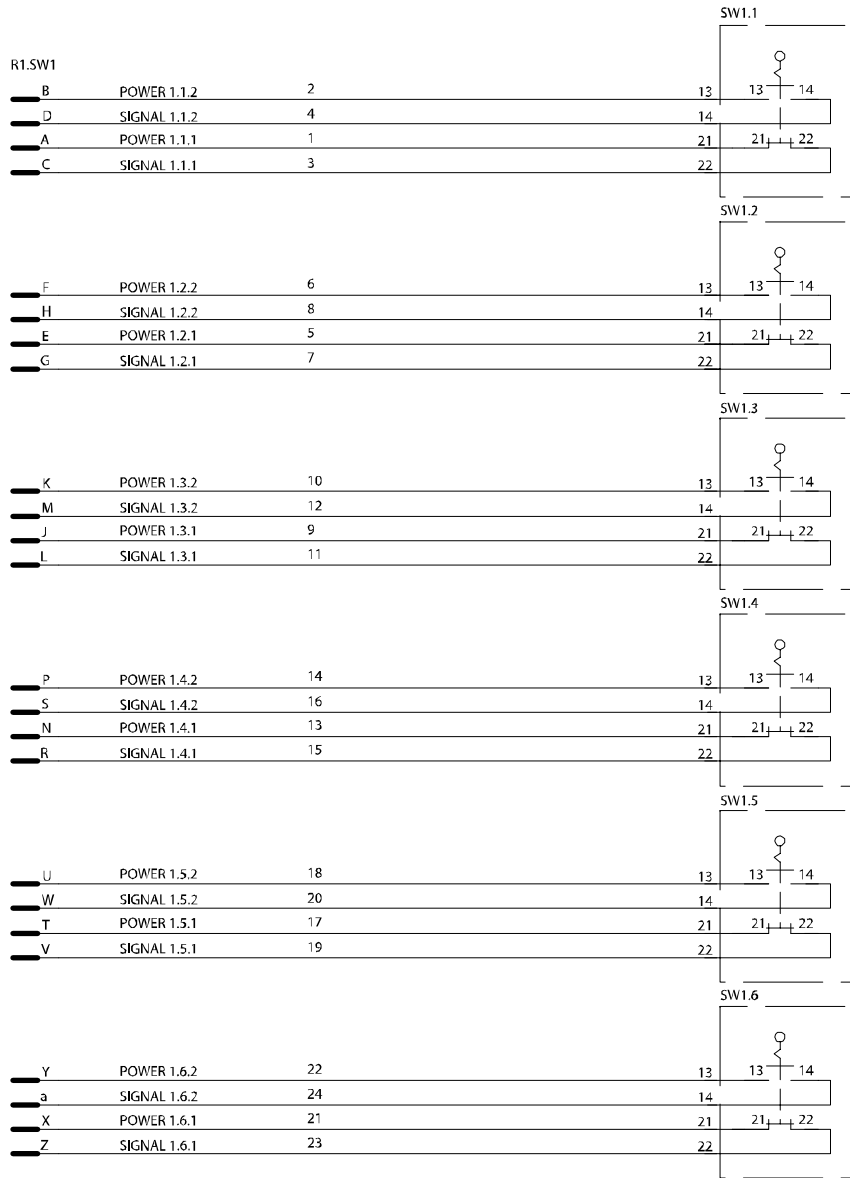

SWITCHES AXIS 1
BRYTARE AXEL 1

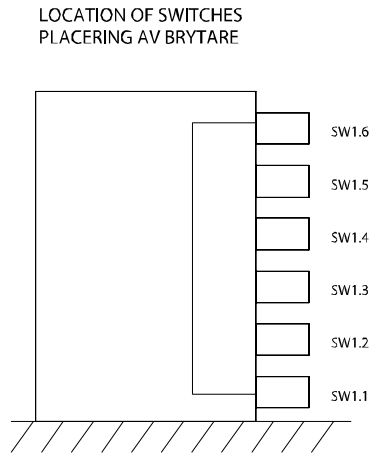

Switches axis 1

sheet	Revision
113	02

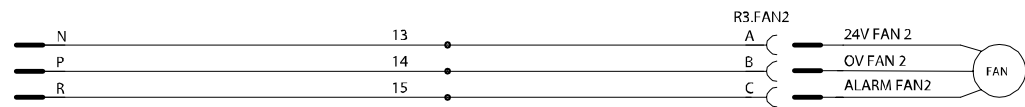
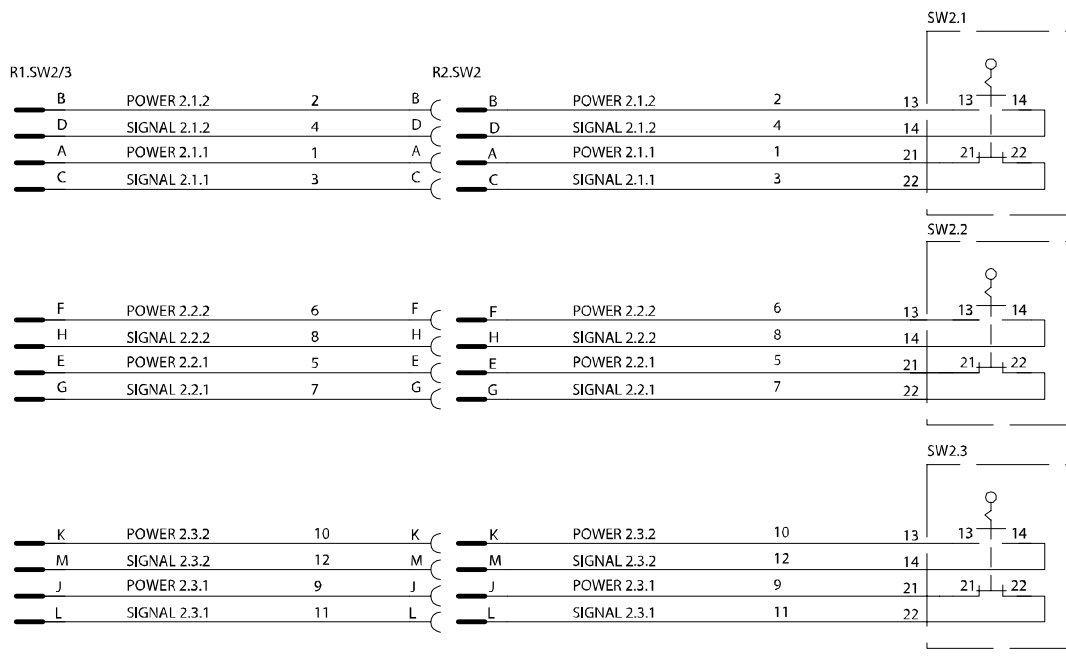

LOCATION OF SWITCHES
PLACERING AV BRYTARE

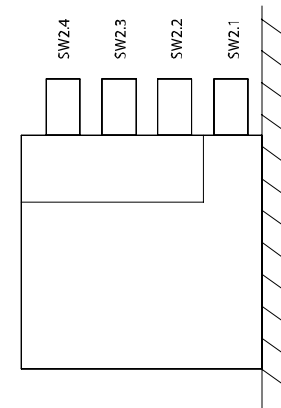

SWITCHES AXIS 2
BRYTARE AXEL 2

FAN AXIS 1 OR 2

Switches/Fan axis 2

sheet		Revision
114		02

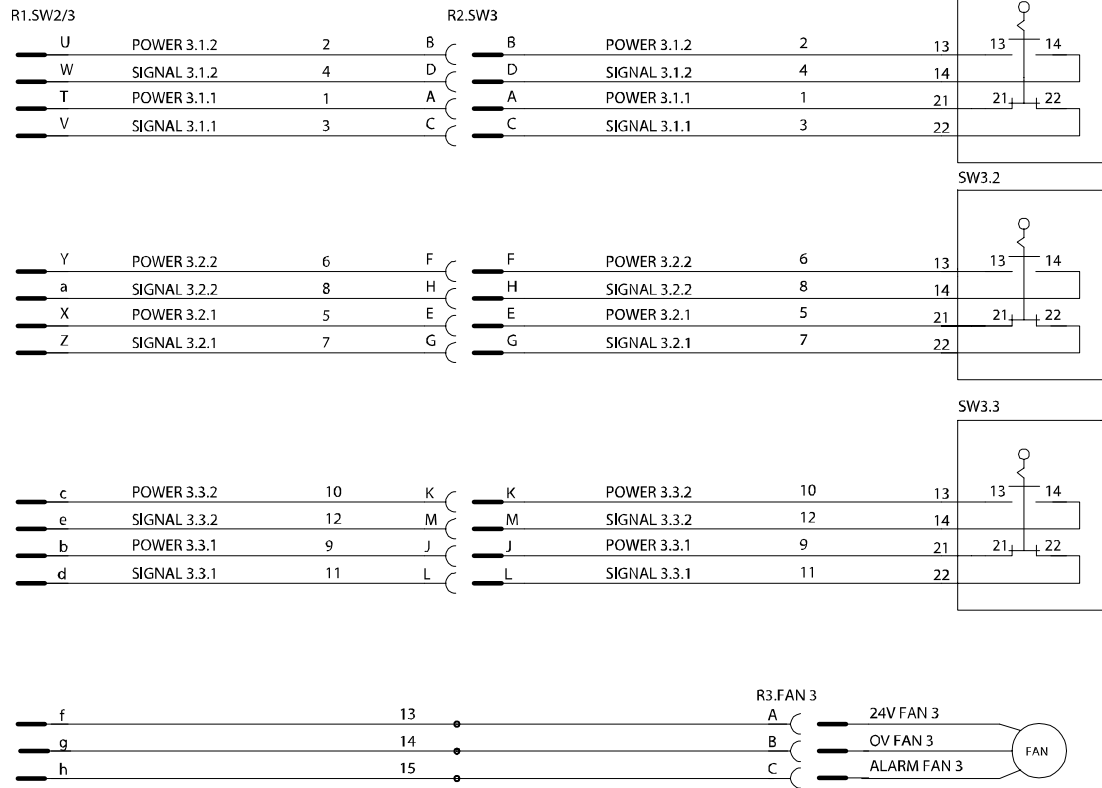

SWITCHES AXIS 3
BRYTARE AXEL 3

FAN AXIS 3
FLÄKT AXEL 3

LOCATION OF SWITCHES
PLACERING AV BRYTARE

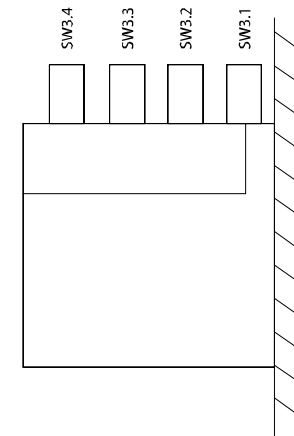

Switches/Fan axis 3

sheet		Revision
115		02

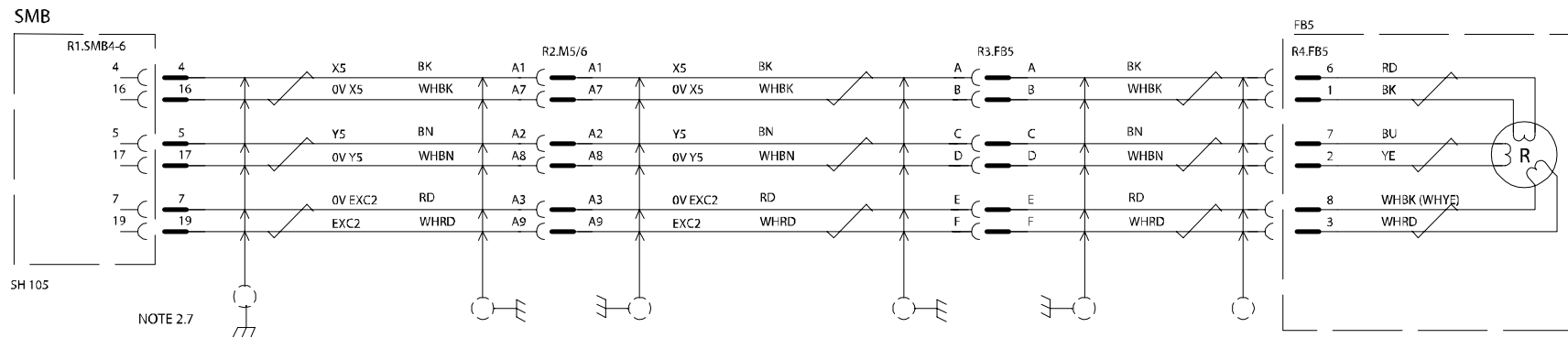
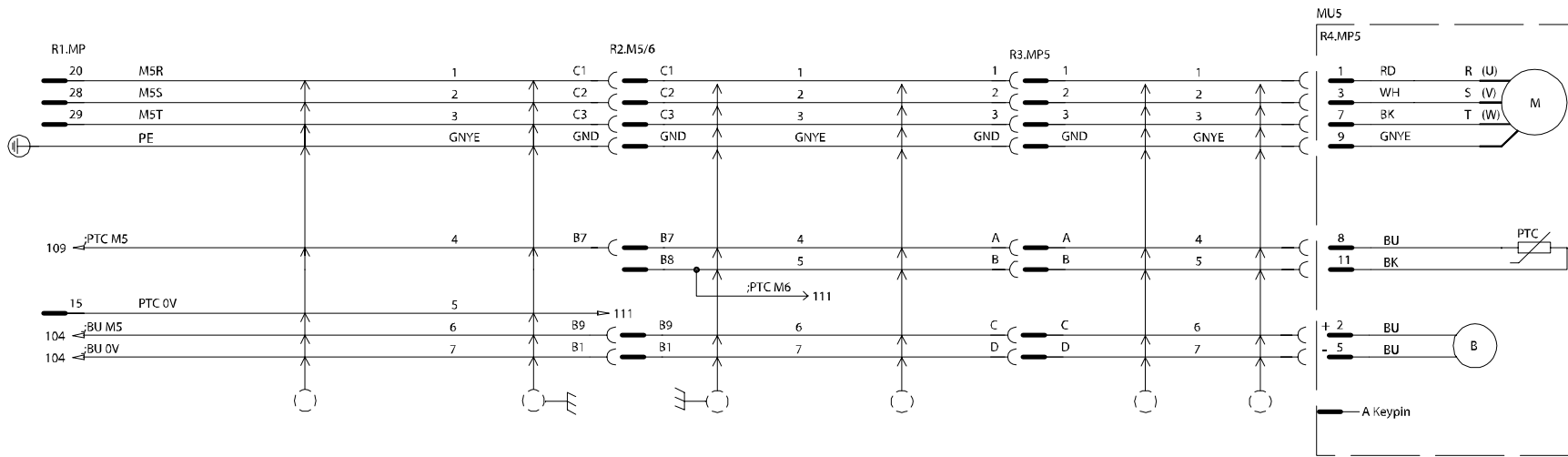

Axis 5 (IRB 6600)

sheet	Revision
901	02

DESIGN BEFORE REV.3 3HAC14940-1 AND REV.1 3HAC16331-1
KONSTRUKTION INNAN REV.3 3HAC14940-1 OCH REV.1 3HAC16331-1

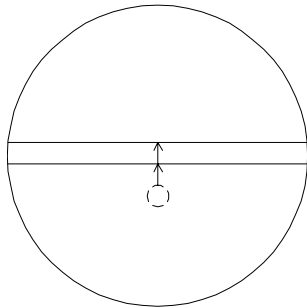

NOTE 1.1

Design changes, note 1.1

sheet		Revision
905		02

DESIGN BEFORE REV.6 3HAC14940-1 AND REV.4 3HAC16331-1
 KONSTRUKTION INNAN REV.6 3HAC14940-1 OCH REV.4 3HAC16331-1

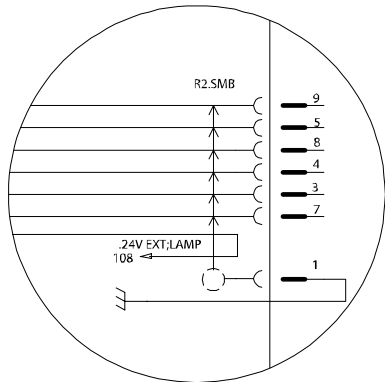

NOTE 2.1

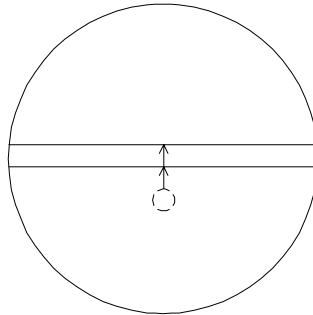

NOTE 2.2

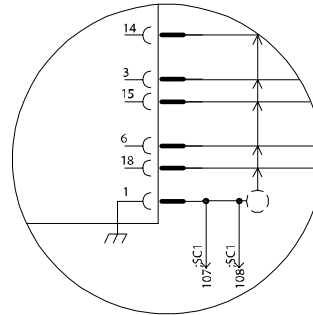

NOTE 2.3

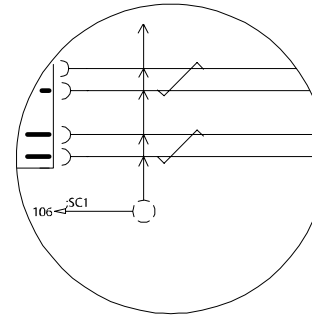

NOTE 2.4

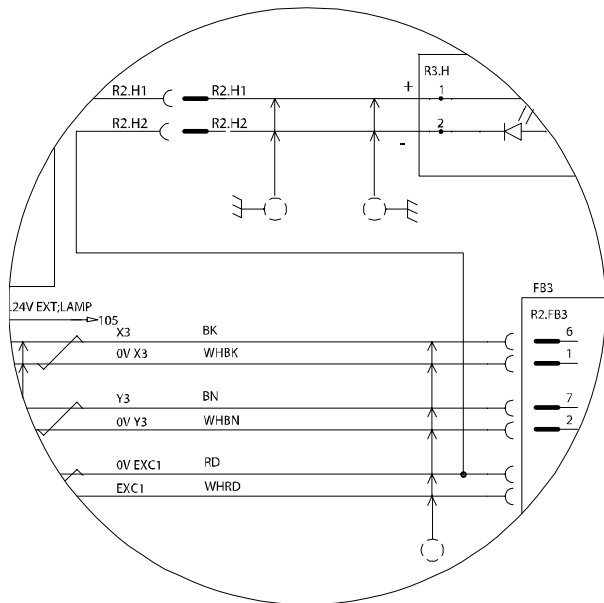

NOTE 2.5

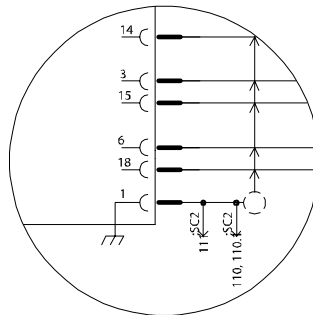

NOTE 2.6

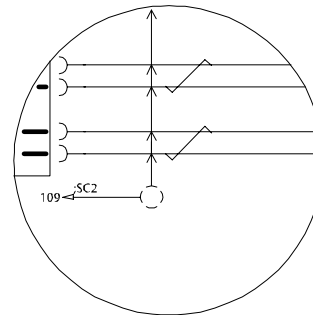

NOTE 2.7

Design changes, note 2.1-2.7

sheet	Revision
906	02